

## Modell 22 FB7



### Use

Model 22 sliding tray for use in high-security areas comprises a hatch with a tray that moves in opposite directions and comes ready for installation. The unit is ideal for high-security use as a counter unit in indoor areas – such as central banks, penal institutions, embassies, and other high-security facilities. The unit is suitable for handing over files, documents, rolls of money and similar objects.

### Safety and features

- Covering shutter which moves in opposite directions, and deep tray for passing through large objects up to 341 x 359 mm in size and up to 100 mm in height, or folders with an 80 mm spine. Automatic lock at full extension in either direction. Lock can only be released by the operator behind the counter by using the lever.
- It is not possible to reach through the hole as the cover and tray change position or manipulate the mechanism.
- Materials offer firearms protection, capable of withstanding heavy gunfire such as a G3 battle rifle. The unit has received M5/FB7 certification from the firearms licensing authority. The integrated steel section means that the area where the unit connects to the glass also offers firearms protection.
- Model 22 fulfils German UVV regulations.

### Materials and use

- Cover made out of 2 mm stainless steel plate.
- Slide, tray and deep tray are made of galvanized stainless steel finished with a special firearms-resistant substance and a black-brown powder coating. The deep tray is strengthened by an additional steel base.
- All metal parts have been produced using state-of-the-art precision laser cutting technology for ultimate quality.
- Model 22 is suitable for use in high-security areas.
- Model 22 requires no maintenance. No need for cleaning or lubrication.

## Sliding trays

**Outer dimensions (all measurements in mm)**

Width 530

Depth 840

Height 185

**Outer dimensions (Model 22 R)**

Width 550

Tiefe 860

Höhe 185

**Deep tray clearance**

Width 342

Depth 205

Height 100

**Weight**

Weight 170 kg

**Miscellaneous**

- Model 22 is also available as Model 22 R, which lies on top of the counter. In this model, the covering shutter is 10mm above the slide.
- Other sizes available on request.

**Modell 22 FB7****Installation and dimensions**

Model 22 comes ready for flush mounting in prepared counter sections. It can be mounted from above or from the counter side. As it contains special substances, the unit is heavy and requires a supporting substructure.

Consideration must be given to access requirements and the possible need to remove the unit later in the unlikely event of repairs.

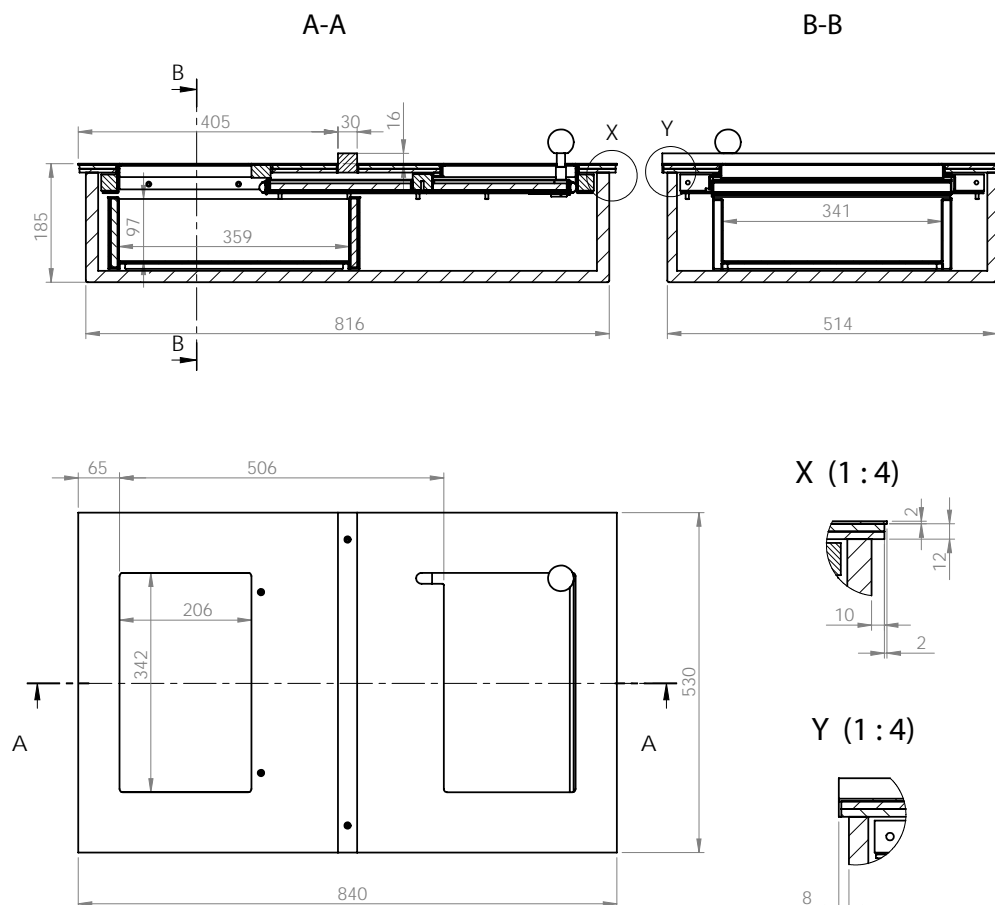
**Walter Wurster GmbH**

Heckenrosenstraße 38

D-70771 Leinfelden-Echterdingen

Telefon: +49 (0) 711 / 9 49 62-0

Telefax: +49 (0) 711 / 7 97 72 90

e-mail: kontakt@IdeeninBlech.de

internet: www.IdeeninBlech.de